

# SN55182, SN75182 DUAL DIFFERENTIAL LINE RECEIVERS

SLLS092D – OCTOBER 1972 – REVISED APRIL 1998

- Single 5-V Supply
- Differential Line Operation
- Dual Channels
- TTL Compatibility
- $\pm 15$ -V Common-Mode Input Voltage Range
- $\pm 15$ -V Differential Input Voltage Range
- Individual Channel Strobes
- Built-In Optional Line-Termination Resistor
- Individual Frequency Response Controls
- Designed for Use With Dual Differential Drivers SN55183 and SN75183
- Designed to Be Interchangeable With National Semiconductor DS7820A and DS8820A

## description

The SN55182 and SN75182 dual differential line receivers are designed to sense small differential signals in the presence of large common-mode noise. These devices give TTL-compatible output signals as a function of the polarity of the differential input voltage. The frequency response of each channel can be easily controlled by a single external capacitor to provide immunity to differential noise spikes. The output goes to a high level when the inputs are open circuited. A strobe input (STRB) is provided that, when in the low level, disables the receiver and forces the output to a high level.

The receiver is of monolithic single-chip construction, and both halves of the dual circuits use common power-supply and ground terminals.

The SN55182 is characterized for operation over the full military temperature range of  $-55^{\circ}\text{C}$  to  $125^{\circ}\text{C}$ . The SN75182 is characterized for operation from  $0^{\circ}\text{C}$  to  $70^{\circ}\text{C}$ .

SN55182 . . . J OR W PACKAGE  
SN75182 . . . N PACKAGE  
(TOP VIEW)

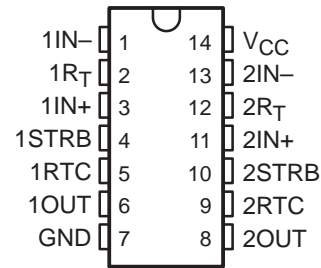

SN55182 . . . FK PACKAGE  
(TOP VIEW)

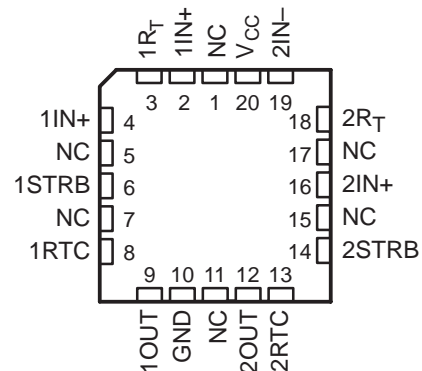

NC – No internal connection

**THE SN55182 IS NOT RECOMMENDED  
FOR NEW DESIGNS**

FUNCTION TABLE

INPUTS		OUTPUT OUT
STRB	V <sub>ID</sub>	
L	X	H
H	H	H
H	L	L

H =  $V_I \geq V_{IH}$  min or  $V_{ID}$  more positive than  $V_{TH}$  max  
L =  $V_I \leq V_{IL}$  max or  $V_{ID}$  more negative than  $V_{TL}$  max  
X = irrelevant



Please be aware that an important notice concerning availability, standard warranty, and use in critical applications of Texas Instruments semiconductor products and disclaimers thereto appears at the end of this data sheet.

PRODUCTION DATA information is current as of publication date. Products conform to specifications per the terms of Texas Instruments standard warranty. Production processing does not necessarily include testing of all parameters.

 **TEXAS  
INSTRUMENTS**

POST OFFICE BOX 655303 • DALLAS, TEXAS 75265

Copyright © 1998, Texas Instruments Incorporated

# SN55182, SN75182 DUAL DIFFERENTIAL LINE RECEIVERS

SLLS092D – OCTOBER 1972 – REVISED APRIL 1998

## logic symbol†

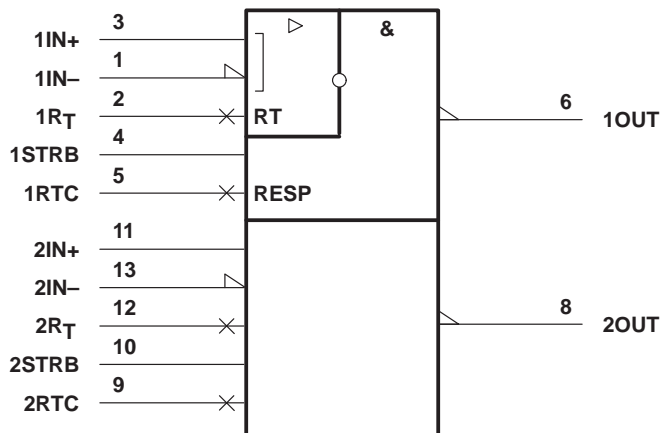

† This symbol is in accordance with ANSI/IEEE Std 91-1984 and IEC Publication 617-12. Pin numbers shown are for the J, N, and W packages.

## logic diagram (positive logic)

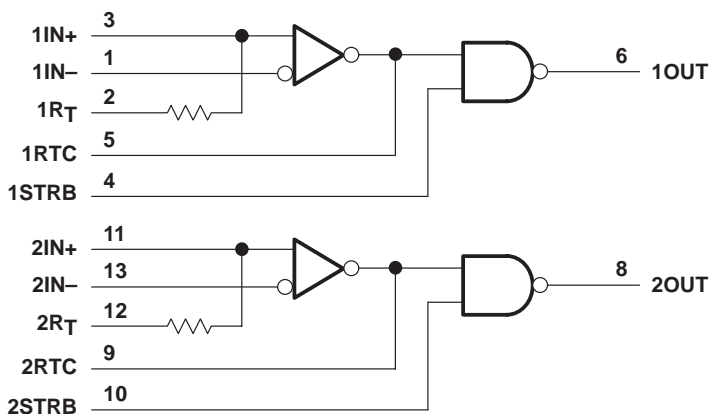

Pin numbers shown are for the J, N, and W packages.

# SN55182, SN75182 DUAL DIFFERENTIAL LINE RECEIVERS

SLLS092D – OCTOBER 1972 – REVISED APRIL 1998

## schematic (each receiver)

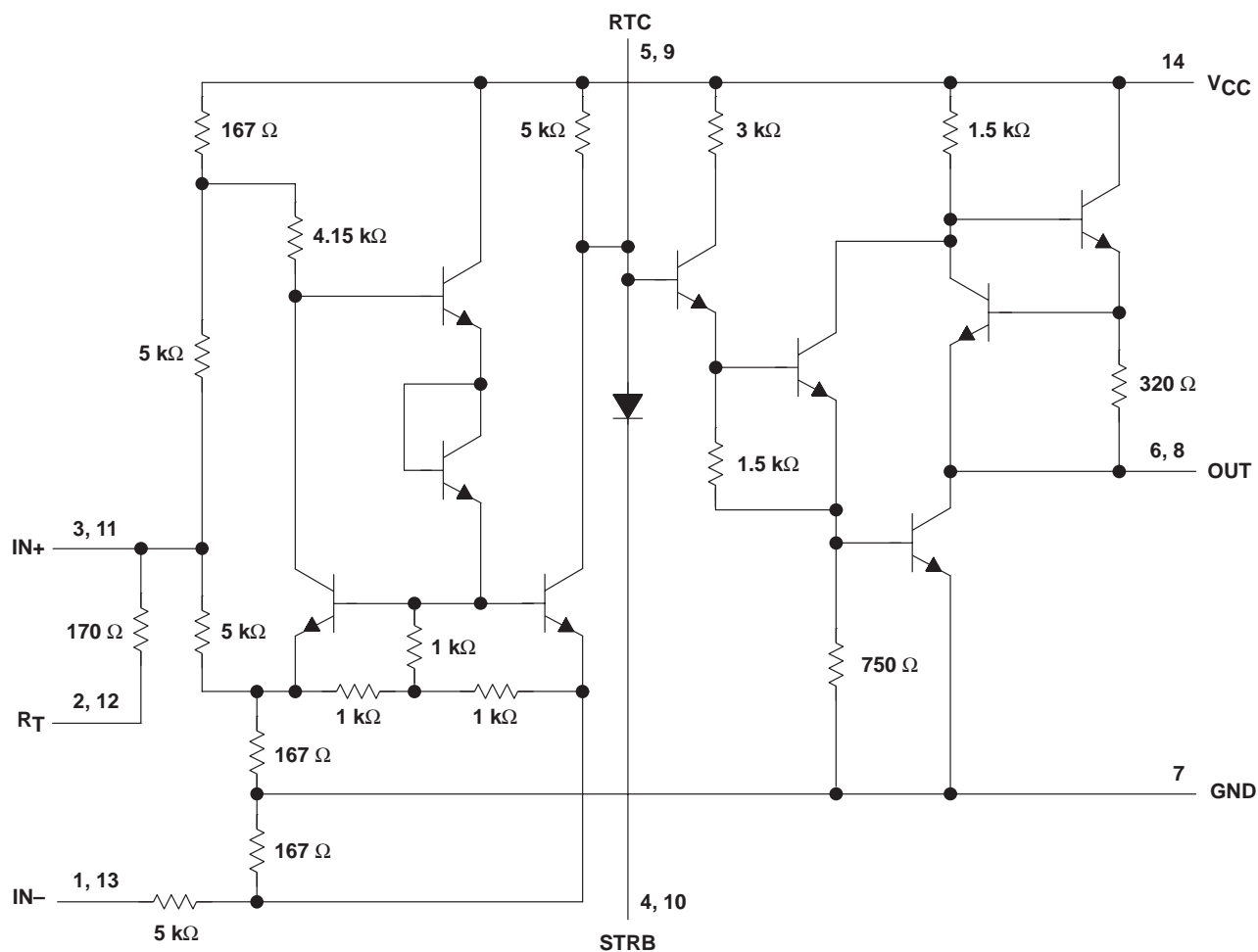

Resistor values shown are nominal.  
Pin numbers shown are for the J, N, and W packages.

# SN55182, SN75182 DUAL DIFFERENTIAL LINE RECEIVERS

SLLS092D – OCTOBER 1972 – REVISED APRIL 1998

## absolute maximum ratings over operating free-air temperature range (unless otherwise noted)†

Supply voltage, $V_{CC}$ (see Note 1)	8 V
Common-mode input voltage, $V_{IC}$	$\pm 20$ V
Differential input voltage, $V_{ID}$ (see Note 2)	$\pm 20$ V
Strobe input voltage, $V_{I(STRB)}$	8 V
Output sink current	50 mA
Continuous total power dissipation	See Dissipation Rating Table
Storage temperature range, $T_{stg}$	$-65^{\circ}\text{C}$ to $150^{\circ}\text{C}$
Lead temperature 1,6 mm (1/16 inch) from case for 10 seconds: N package	$260^{\circ}\text{C}$
Lead temperature 1,6 mm (1/16 inch) from case for 60 seconds: J or W package	$300^{\circ}\text{C}$
Case temperature for 60 seconds, $T_C$ : FK package	$260^{\circ}\text{C}$

† Stresses beyond those listed under "absolute maximum ratings" may cause permanent damage to the device. These are stress ratings only, and functional operation of the device at these or any other conditions beyond those indicated under "recommended operating conditions" is not implied. Exposure to absolute-maximum-rated conditions for extended periods may affect device reliability.

- NOTES: 1. All voltage values, except differential voltages, are with respect to network ground terminal.  
2. Differential voltage values are at the noninverting terminal with respect to the inverting terminal.

DISSIPATION RATING TABLE

PACKAGE	$T_A \leq 25^{\circ}\text{C}$	DERATING FACTOR	$T_A = 70^{\circ}\text{C}$	$T_A = 125^{\circ}\text{C}$
	POWER RATING	ABOVE $T_A = 25^{\circ}\text{C}$	POWER RATING	POWER RATING
FK‡	1375 mW	11.0 mW/ $^{\circ}\text{C}$	880 mW	275 mW
J‡	1375 mW	11.0 mW/ $^{\circ}\text{C}$	880 mW	275 mW
N	1150 mW	9.2 mW/ $^{\circ}\text{C}$	736 mW	–
W‡	1000 mW	8.0 mW/ $^{\circ}\text{C}$	640 mW	200 mW

‡ In the FK, J, and W packages, SN55182 chips are alloy mounted.

## recommended operating conditions

	SN55182			SN75182			UNIT
	MIN	NOM	MAX	MIN	NOM	MAX	
Supply voltage, $V_{CC}$	4.5	5	5.5	4.5	5	5.5	V
Common-mode input voltage, $V_{IC}$			$\pm 15$			$\pm 15$	V
High-level strobe input voltage, $V_{IH(STRB)}$	2.1		5.5	2.1		5.5	V
Low-level strobe input voltage, $V_{IL(STRB)}$	0		0.9	0		0.9	V
High-level output current, $I_{OH}$			–400			–400	$\mu\text{A}$
Low-level output current, $I_{OL}$			16			16	mA
Operating free-air temperature, $T_A$	–55		125	0		70	$^{\circ}\text{C}$



# SN55182, SN75182 DUAL DIFFERENTIAL LINE RECEIVERS

SLLS092D – OCTOBER 1972 – REVISED APRIL 1998

**electrical characteristics over recommended ranges of  $V_{CC}$ ,  $V_{IC}$ , and operating free-air temperature (unless otherwise noted)**

PARAMETER		TEST CONDITIONS†	MIN	TYP‡	MAX	UNIT		
$V_{IT+}$	Positive-going input threshold voltage	$V_O = 2.5\text{ V}$ , $I_{OH} = -400\ \mu\text{A}$	$V_{IC} = -3\text{ V to }3\text{ V}$		0.5	V		
			$V_{IC} = -15\text{ V to }15\text{ V}$		1			
$V_{IT-}$	Negative-going input threshold voltage	$V_O = 0.4\text{ V}$ , $I_{OL} = 16\text{ mA}$	$V_{IC} = -3\text{ V to }3\text{ V}$		-0.5	V		
			$V_{IC} = -15\text{ V to }15\text{ V}$		-1			
$V_{OH}$	High-level output voltage	$V_{ID} = 1\text{ V}$ , $V(\text{STRB}) = 2.1\text{ V}$ , $I_{OH} = -400\ \mu\text{A}$		2.5	4.2	5.5	V	
		$V_{ID} = -1\text{ V}$ , $V(\text{STRB}) = 0.4\text{ V}$ , $I_{OH} = -400\ \mu\text{A}$		2.5	4.2	5.5		
$V_{OL}$	Low-level output voltage	$V_{ID} = -1\text{ V}$ , $V(\text{STRB}) = 2.1\text{ V}$ , $I_{OL} = 16\text{ mA}$		0.25	0.4	V		
$I_I$	Input current	$V_{IC} = 15\text{ V}$	Inverting input	$V_{IC} = 0$		3	4.2	mA
				$V_{IC} = -15\text{ V}$		0	-0.5	
						-3	-4.2	
			Noninverting input	$V_{IC} = 15\text{ V}$		5	7	
				$V_{IC} = 0$		-1	-1.4	
				$V_{IC} = -15\text{ V}$		-7	-9.8	
$I_{IH}(\text{STRB})$	High-level strobe input current	$V(\text{STRB}) = 5.5\text{ V}$			5	$\mu\text{A}$		
$I_{IL}(\text{STRB})$	Low-level strobe input current	$V(\text{STRB}) = 0$			-1	-1.4	mA	
$r_i$	Input resistance		Inverting input		3.6	5	k $\Omega$	
			Noninverting input		1.8	2.5		
	Line-terminating resistance	$T_A = 25^\circ\text{C}$		120	170	250	$\Omega$	
$I_{OS}$	Short-circuit output current	$V_{CC} = 5.5\text{ V}$ , $V_O = 0$		-2.8	-4.5	-6.7	mA	
$I_{CC}$	Supply current (average per receiver)	$V_{IC} = 15\text{ V}$ , $V_{ID} = -1\text{ V}$		4.2	6	mA		
		$V_{IC} = 0$ , $V_{ID} = -0.5\text{ V}$		6.8	10.2			
		$V_{IC} = -15\text{ V}$ , $V_{ID} = -1\text{ V}$		9.4	14			

† Unless otherwise noted,  $V(\text{STRB}) \geq 2.1\text{ V}$  or open.

‡ All typical values are at  $V_{CC} = 5\text{ V}$ ,  $V_{IC} = 0$ , and  $T_A = 25^\circ\text{C}$ .

## switching characteristics, $V_{CC} = 5\text{ V}$ , $T_A = 25^\circ\text{C}$

PARAMETER		TEST CONDITIONS	MIN	TYP	MAX	UNIT
$t_{PLH}(\text{D})$	Propagation delay time, low- to high-level output from differential input	$R_L = 400\ \Omega$ , $C_L = 15\text{ pF}$ , see Figure 1		18	40	ns
$t_{PHL}(\text{D})$	Propagation delay time, high- to low-level output from differential input	$R_L = 400\ \Omega$ , $C_L = 15\text{ pF}$ , see Figure 1		31	45	ns
$t_{PLH}(\text{S})$	Propagation delay time, low- to high-level output from STRB input	$R_L = 400\ \Omega$ , $C_L = 15\text{ pF}$ , see Figure 1		9	30	ns
$t_{PHL}(\text{S})$	Propagation delay time, high- to low-level output from STRB input	$R_L = 400\ \Omega$ , $C_L = 15\text{ pF}$ , see Figure 1		15	25	ns

# SN55182, SN75182 DUAL DIFFERENTIAL LINE RECEIVERS

SLLS092D – OCTOBER 1972 – REVISED APRIL 1998

## PARAMETER MEASUREMENT INFORMATION

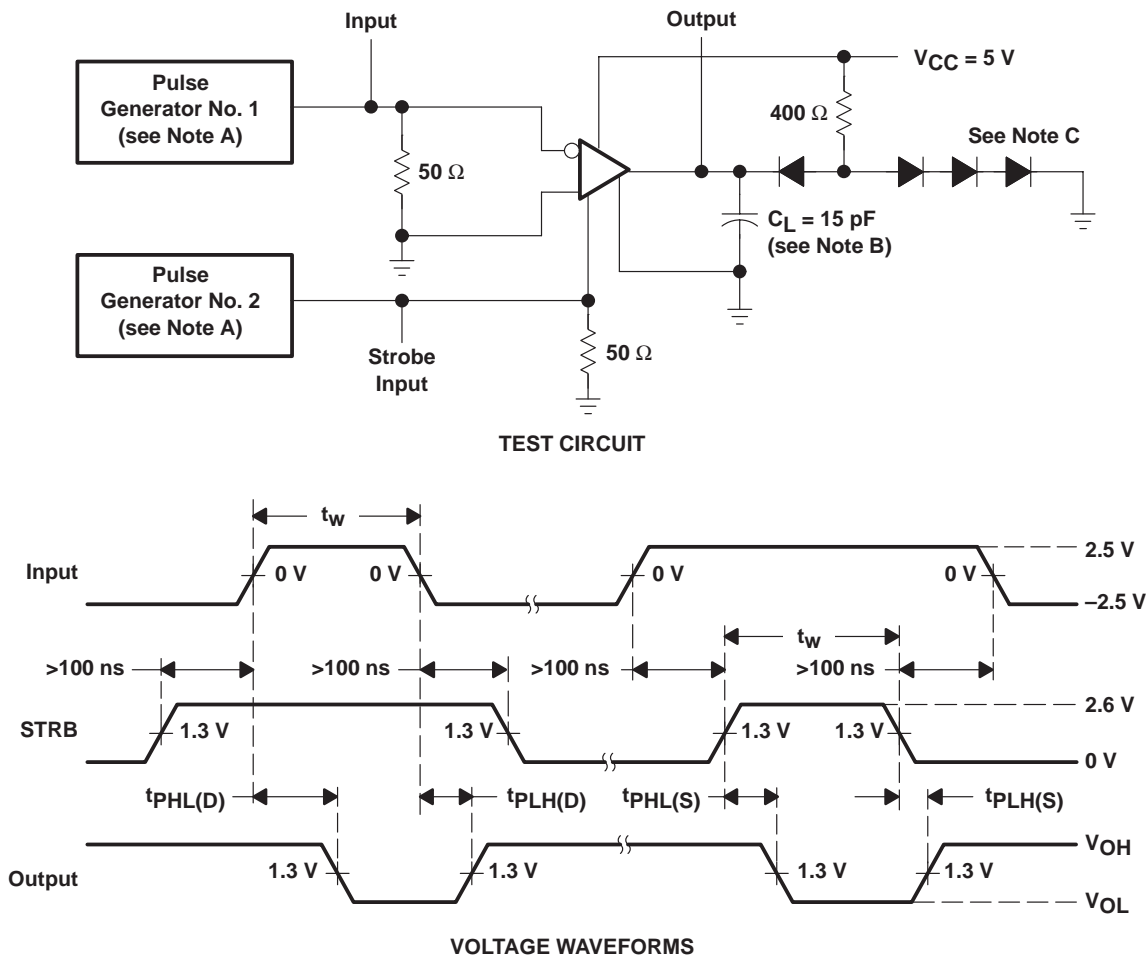

- NOTES: A. The pulse generators have the following characteristics:  $Z_O = 50 \Omega$ ,  $t_r \leq 10 \text{ ns}$ ,  $t_f \leq 10 \text{ ns}$ ,  $t_w = 0.5 \pm 0.1 \mu\text{s}$ ,  $\text{PRR} \leq 1 \text{ MHz}$ .  
 B.  $C_L$  includes probe and jig capacitance.  
 C. All diodes are 1N3064 or equivalent.

**Figure 1. Test Circuit and Voltage Waveforms**

TYPICAL CHARACTERISTICS†

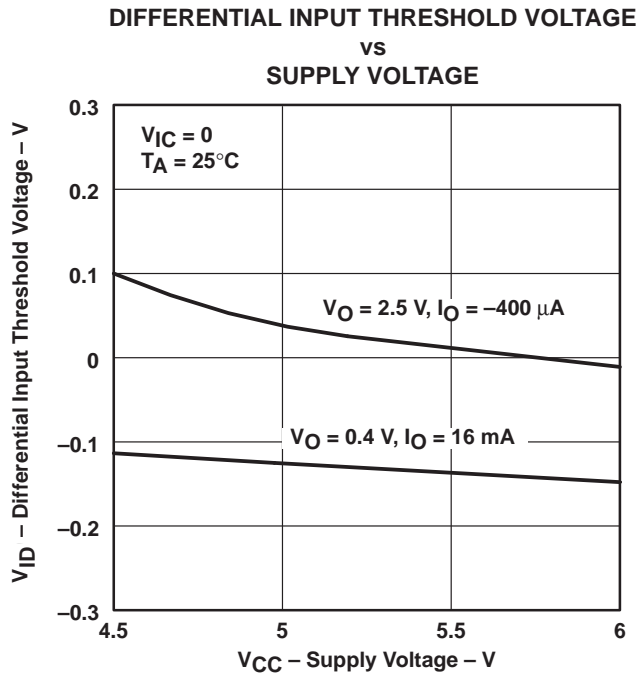

Figure 2

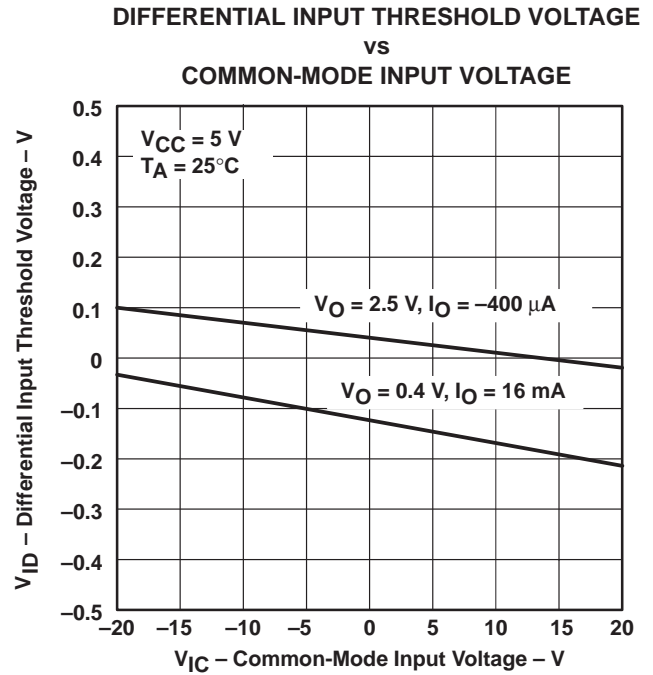

Figure 3

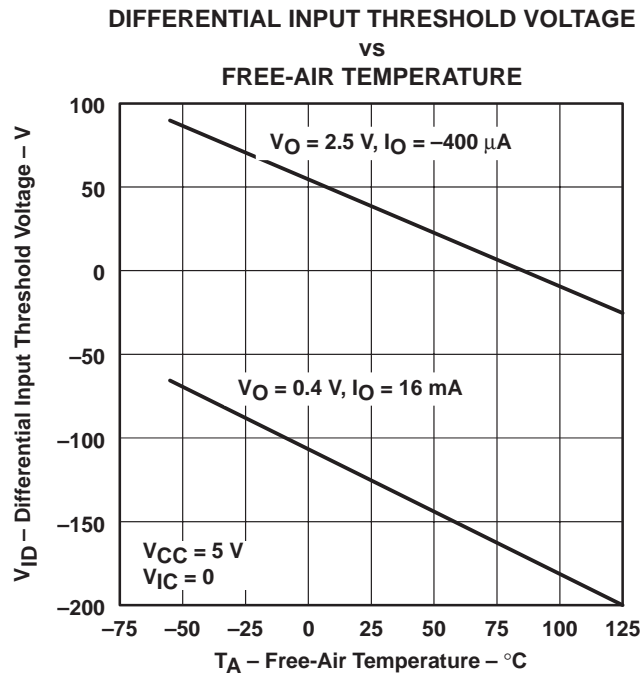

Figure 4

† Operation of the device at these or any other conditions beyond those indicated under "recommended operating conditions" is not implied.

# SN55182, SN75182 DUAL DIFFERENTIAL LINE RECEIVERS

SLLS092D – OCTOBER 1972 – REVISED APRIL 1998

## TYPICAL CHARACTERISTICS†

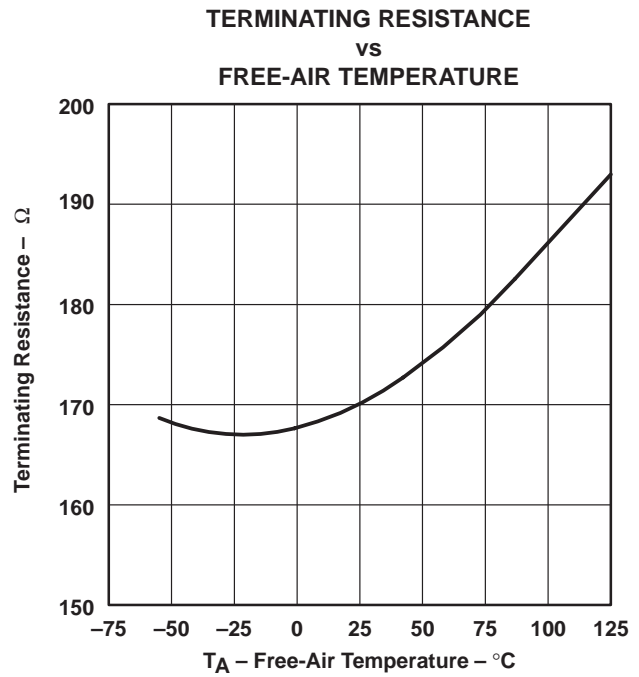
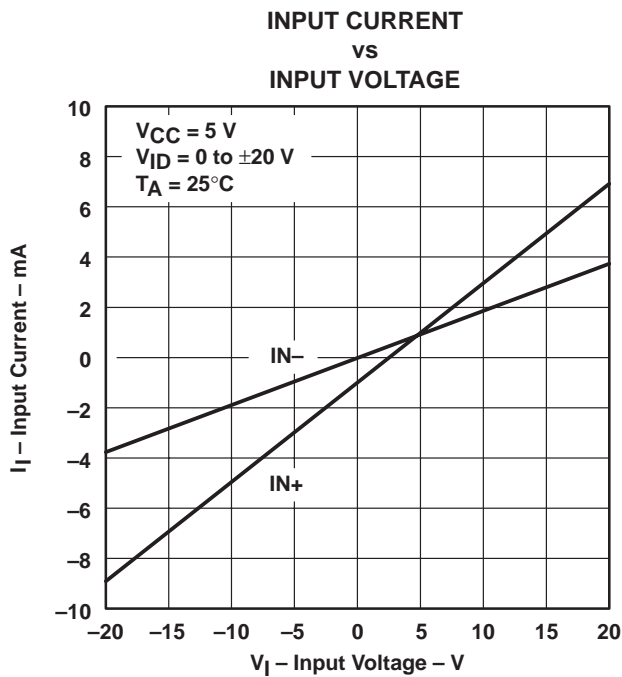
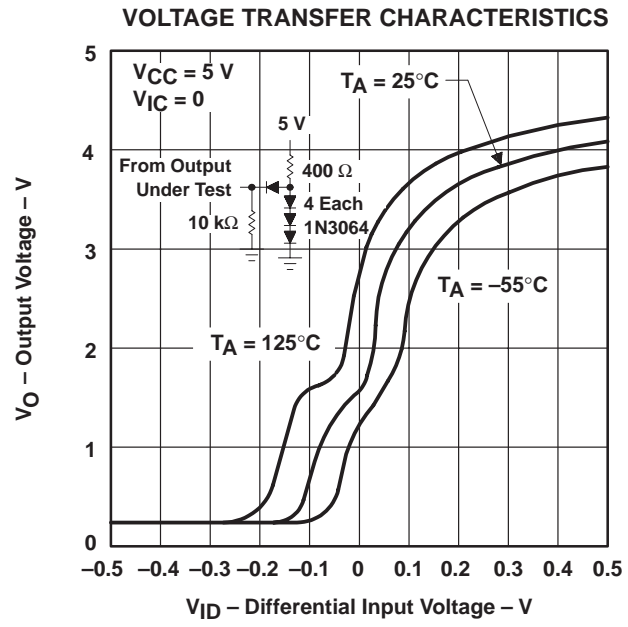
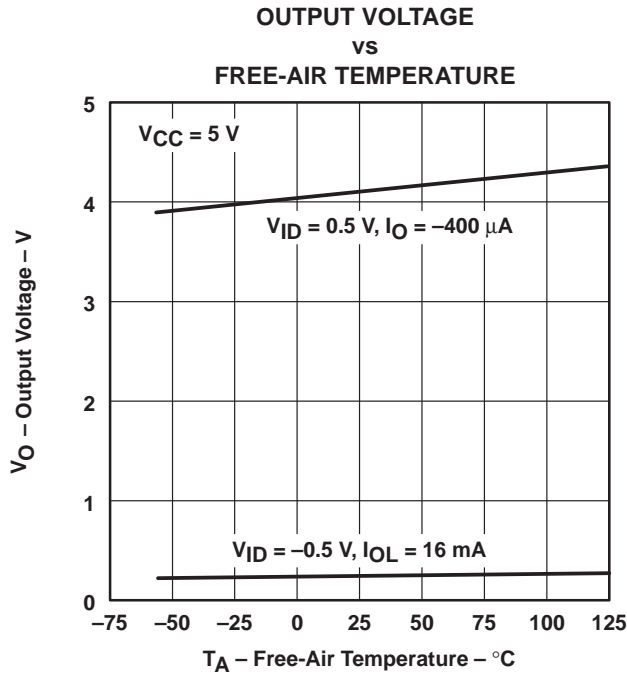

† Operation of the device at these or any other conditions beyond those indicated under "recommended operating conditions" is not implied.

TYPICAL CHARACTERISTICS†

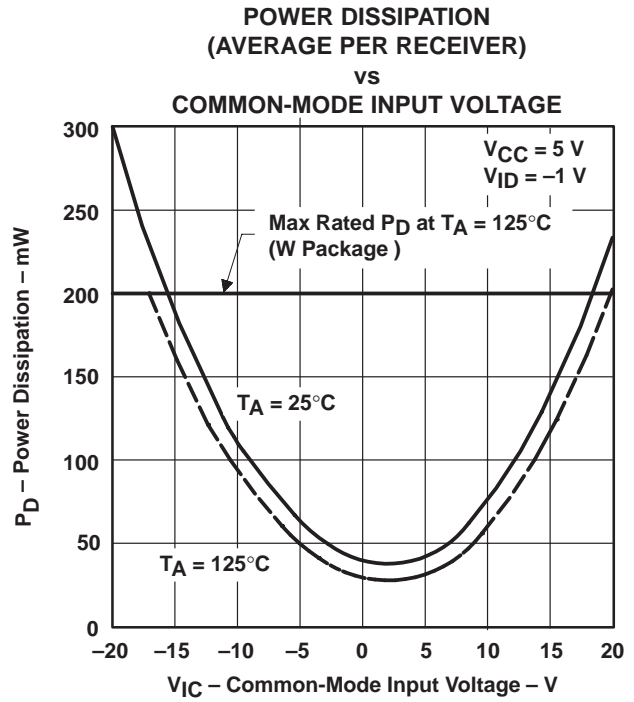
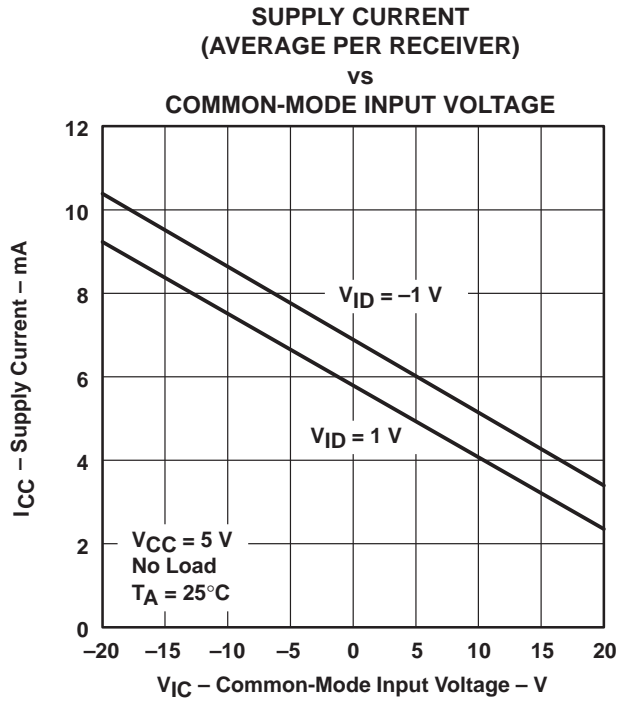

† Operation of the device at these or any other conditions beyond those indicated under "recommended operating conditions" is not implied.

# SN55182, SN75182 DUAL DIFFERENTIAL LINE RECEIVERS

SLLS092D – OCTOBER 1972 – REVISED APRIL 1998

## TYPICAL CHARACTERISTICS†

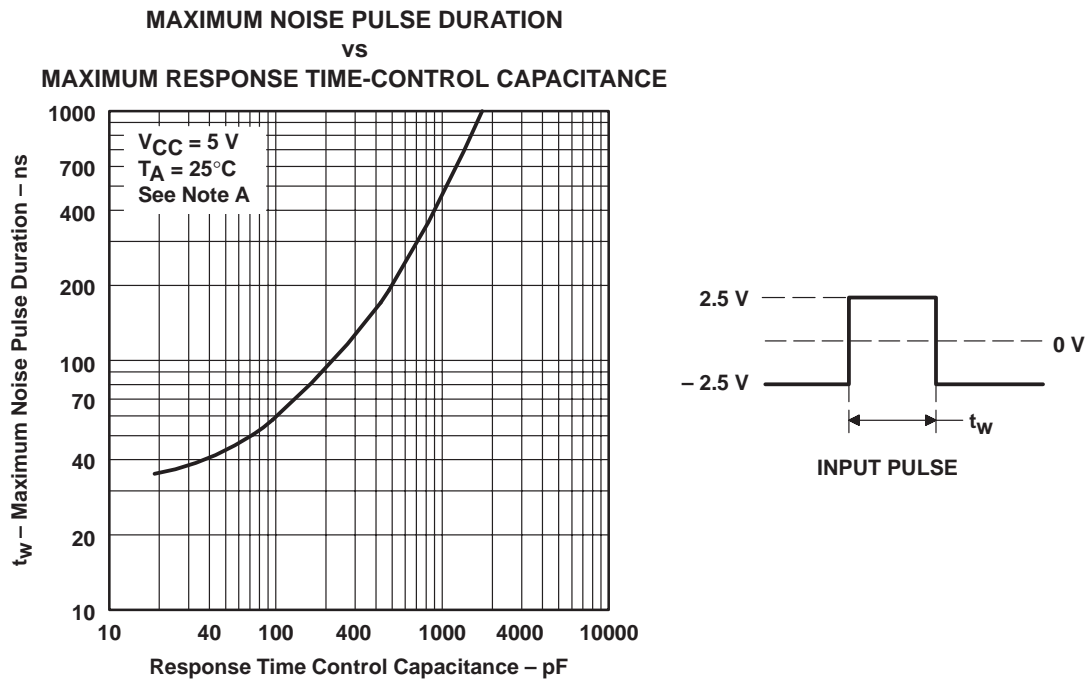

NOTE A: Figure 11 shows the maximum duration of the illustrated pulse that can be applied differently without the output changing from the low to high level.

**Figure 11**

† Operation of the device at these or any other conditions beyond those indicated under "recommended operating conditions" is not implied.

TYPICAL CHARACTERISTICS†

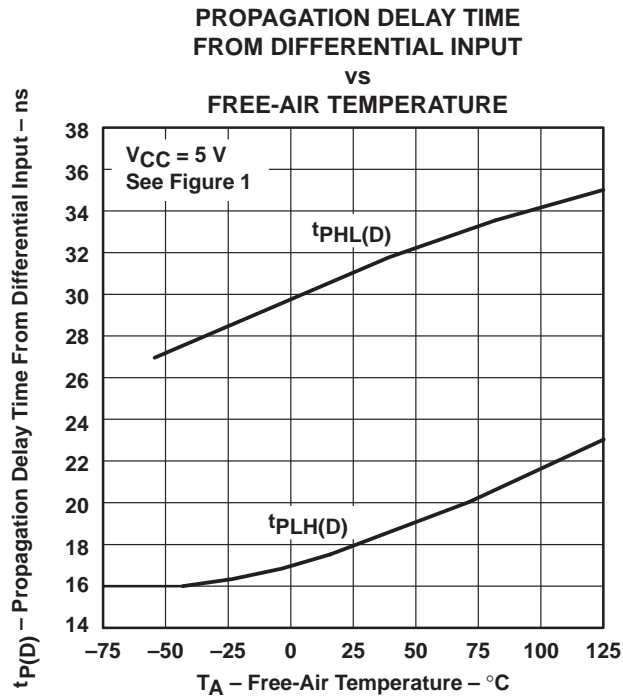

Figure 12

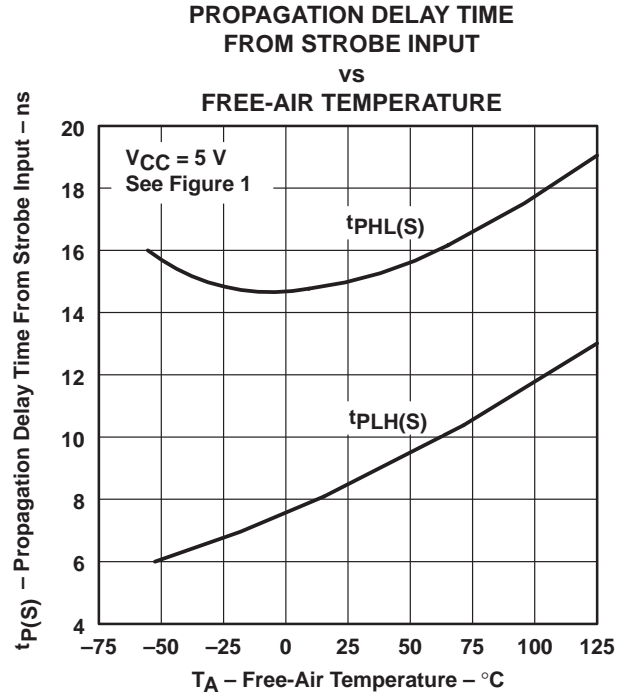

Figure 13

† Operation of the device at these or any other conditions beyond those indicated under "recommended operating conditions" is not implied.

# SN55182, SN75182 DUAL DIFFERENTIAL LINE RECEIVERS

SLLS092D – OCTOBER 1972 – REVISED APRIL 1998

## APPLICATION INFORMATION

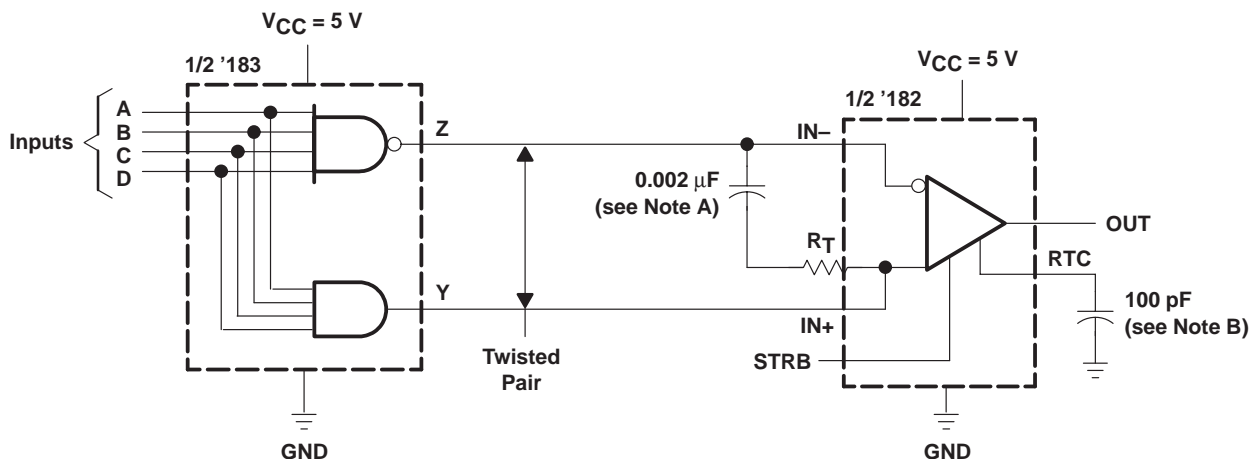

NOTES: A. When the inputs are open circuited, the output is high. A capacitor may be used for dc isolation of the line-terminating resistor. At the frequency of operation, the impedance of the capacitor should be relatively small.

Example: let  $f = 5 \text{ MHz}$   
 $C = 0.002 \mu\text{F}$

$$Z_{(C)} = \frac{1}{2\pi f C} = \frac{1}{2\pi(5 \times 10^6)(0.002 \times 10^{-6})}$$

$$Z_{(C)} \approx 16\Omega$$

B. Use of a capacitor to control response time is optional.

**Figure 14. Transmission of Digital Data Over Twisted-Pair Line**

**PACKAGING INFORMATION**

Orderable Device	Status (1)	Package Type	Package Drawing	Pins	Package Qty	Eco Plan (2)	Lead/Ball Finish (6)	MSL Peak Temp (3)	Op Temp (°C)	Device Marking (4/5)	Samples
5962-7900801VCA	ACTIVE	CDIP	J	14	1	TBD	A42	N / A for Pkg Type	-55 to 125	5962-7900801VC A SNV55182J	<a href="#">Samples</a>
5962-7900801VDA	ACTIVE	CFP	W	14	25	TBD	A42	N / A for Pkg Type	-55 to 125	5962-7900801VD A SNV55182W	<a href="#">Samples</a>
SN75182D	ACTIVE	SOIC	D	14	50	Green (RoHS & no Sb/Br)	CU NIPDAU	Level-1-260C-UNLIM	0 to 70	SN75182	<a href="#">Samples</a>
SN75182DG4	ACTIVE	SOIC	D	14	50	Green (RoHS & no Sb/Br)	CU NIPDAU	Level-1-260C-UNLIM	0 to 70	SN75182	<a href="#">Samples</a>
SN75182DR	ACTIVE	SOIC	D	14	2500	Green (RoHS & no Sb/Br)	CU NIPDAU	Level-1-260C-UNLIM	0 to 70	SN75182	<a href="#">Samples</a>
SN75182DRE4	ACTIVE	SOIC	D	14	2500	Green (RoHS & no Sb/Br)	CU NIPDAU	Level-1-260C-UNLIM	0 to 70	SN75182	<a href="#">Samples</a>
SN75182N	ACTIVE	PDIP	N	14	25	Pb-Free (RoHS)	CU NIPDAU	N / A for Pkg Type	0 to 70	SN75182N	<a href="#">Samples</a>
SN75182NE4	ACTIVE	PDIP	N	14	25	Pb-Free (RoHS)	CU NIPDAU	N / A for Pkg Type	0 to 70	SN75182N	<a href="#">Samples</a>
SN75182NSR	ACTIVE	SO	NS	14	2000	Green (RoHS & no Sb/Br)	CU NIPDAU	Level-1-260C-UNLIM	0 to 70	SN75182	<a href="#">Samples</a>

(1) The marketing status values are defined as follows:

**ACTIVE:** Product device recommended for new designs.

**LIFEBUY:** TI has announced that the device will be discontinued, and a lifetime-buy period is in effect.

**NRND:** Not recommended for new designs. Device is in production to support existing customers, but TI does not recommend using this part in a new design.

**PREVIEW:** Device has been announced but is not in production. Samples may or may not be available.

**OBSOLETE:** TI has discontinued the production of the device.

(2) Eco Plan - The planned eco-friendly classification: Pb-Free (RoHS), Pb-Free (RoHS Exempt), or Green (RoHS & no Sb/Br) - please check <http://www.ti.com/productcontent> for the latest availability information and additional product content details.

**TBD:** The Pb-Free/Green conversion plan has not been defined.

**Pb-Free (RoHS):** TI's terms "Lead-Free" or "Pb-Free" mean semiconductor products that are compatible with the current RoHS requirements for all 6 substances, including the requirement that lead not exceed 0.1% by weight in homogeneous materials. Where designed to be soldered at high temperatures, TI Pb-Free products are suitable for use in specified lead-free processes.

**Pb-Free (RoHS Exempt):** This component has a RoHS exemption for either 1) lead-based flip-chip solder bumps used between the die and package, or 2) lead-based die adhesive used between the die and leadframe. The component is otherwise considered Pb-Free (RoHS compatible) as defined above.

**Green (RoHS & no Sb/Br):** TI defines "Green" to mean Pb-Free (RoHS compatible), and free of Bromine (Br) and Antimony (Sb) based flame retardants (Br or Sb do not exceed 0.1% by weight in homogeneous material)

- (3) MSL, Peak Temp. - The Moisture Sensitivity Level rating according to the JEDEC industry standard classifications, and peak solder temperature.
- (4) There may be additional marking, which relates to the logo, the lot trace code information, or the environmental category on the device.
- (5) Multiple Device Markings will be inside parentheses. Only one Device Marking contained in parentheses and separated by a "~" will appear on a device. If a line is indented then it is a continuation of the previous line and the two combined represent the entire Device Marking for that device.
- (6) Lead/Ball Finish - Orderable Devices may have multiple material finish options. Finish options are separated by a vertical ruled line. Lead/Ball Finish values may wrap to two lines if the finish value exceeds the maximum column width.

**Important Information and Disclaimer:**The information provided on this page represents TI's knowledge and belief as of the date that it is provided. TI bases its knowledge and belief on information provided by third parties, and makes no representation or warranty as to the accuracy of such information. Efforts are underway to better integrate information from third parties. TI has taken and continues to take reasonable steps to provide representative and accurate information but may not have conducted destructive testing or chemical analysis on incoming materials and chemicals. TI and TI suppliers consider certain information to be proprietary, and thus CAS numbers and other limited information may not be available for release.

In no event shall TI's liability arising out of such information exceed the total purchase price of the TI part(s) at issue in this document sold by TI to Customer on an annual basis.

## TAPE AND REEL INFORMATION

### REEL DIMENSIONS



### TAPE DIMENSIONS



A0	Dimension designed to accommodate the component width
B0	Dimension designed to accommodate the component length
K0	Dimension designed to accommodate the component thickness
W	Overall width of the carrier tape
P1	Pitch between successive cavity centers

### TAPE AND REEL INFORMATION

\*All dimensions are nominal

Device	Package Type	Package Drawing	Pins	SPQ	Reel Diameter (mm)	Reel Width W1 (mm)	A0 (mm)	B0 (mm)	K0 (mm)	P1 (mm)	W (mm)	Pin1 Quadrant
SN75182DR	SOIC	D	14	2500	330.0	16.4	6.5	9.0	2.1	8.0	16.0	Q1
SN75182NSR	SO	NS	14	2000	330.0	16.4	8.2	10.5	2.5	12.0	16.0	Q1

**TAPE AND REEL BOX DIMENSIONS**

\*All dimensions are nominal

Device	Package Type	Package Drawing	Pins	SPQ	Length (mm)	Width (mm)	Height (mm)
SN75182DR	SOIC	D	14	2500	367.0	367.0	38.0
SN75182NSR	SO	NS	14	2000	367.0	367.0	38.0

J (R-GDIP-T\*\*)

14 LEADS SHOWN

CERAMIC DUAL IN-LINE PACKAGE



DIM \ PINS **	14	16	18	20
A	0.300 (7,62) BSC	0.300 (7,62) BSC	0.300 (7,62) BSC	0.300 (7,62) BSC
B MAX	0.785 (19,94)	.840 (21,34)	0.960 (24,38)	1.060 (26,92)
B MIN	—	—	—	—
C MAX	0.300 (7,62)	0.300 (7,62)	0.310 (7,87)	0.300 (7,62)
C MIN	0.245 (6,22)	0.245 (6,22)	0.220 (5,59)	0.245 (6,22)



4040083/F 03/03

- NOTES:
- A. All linear dimensions are in inches (millimeters).
  - B. This drawing is subject to change without notice.
  - C. This package is hermetically sealed with a ceramic lid using glass frit.
  - D. Index point is provided on cap for terminal identification only on press ceramic glass frit seal only.
  - E. Falls within MIL STD 1835 GDIP1-T14, GDIP1-T16, GDIP1-T18 and GDIP1-T20.

W (R-GDFP-F14)

CERAMIC DUAL FLATPACK



- NOTES:
- A. All linear dimensions are in inches (millimeters).
  - B. This drawing is subject to change without notice.
  - C. This package can be hermetically sealed with a ceramic lid using glass frit.
  - D. Index point is provided on cap for terminal identification only.
  - E. Falls within MIL STD 1835 GDFP1-F14



D (R-PDSO-G14)

PLASTIC SMALL OUTLINE



4211283-3/E 08/12

- NOTES:
- All linear dimensions are in millimeters.
  - This drawing is subject to change without notice.
  - Publication IPC-7351 is recommended for alternate designs.
  - Laser cutting apertures with trapezoidal walls and also rounding corners will offer better paste release. Customers should contact their board assembly site for stencil design recommendations. Refer to IPC-7525 for other stencil recommendations.
  - Customers should contact their board fabrication site for solder mask tolerances between and around signal pads.

N (R-PDIP-T\*\*)

PLASTIC DUAL-IN-LINE PACKAGE

16 PINS SHOWN



- NOTES:
- A. All linear dimensions are in inches (millimeters).
  - B. This drawing is subject to change without notice.
  - C Falls within JEDEC MS-001, except 18 and 20 pin minimum body length (Dim A).
  - D The 20 pin end lead shoulder width is a vendor option, either half or full width.

4040049/E 12/2002

# MECHANICAL DATA

NS (R-PDSO-G\*\*)

PLASTIC SMALL-OUTLINE PACKAGE

14-PINS SHOWN



- NOTES:
- A. All linear dimensions are in millimeters.
  - B. This drawing is subject to change without notice.
  - C. Body dimensions do not include mold flash or protrusion, not to exceed 0,15.

## IMPORTANT NOTICE

Texas Instruments Incorporated (TI) reserves the right to make corrections, enhancements, improvements and other changes to its semiconductor products and services per JESD46, latest issue, and to discontinue any product or service per JESD48, latest issue. Buyers should obtain the latest relevant information before placing orders and should verify that such information is current and complete.

TI's published terms of sale for semiconductor products (<http://www.ti.com/sc/docs/stdterms.htm>) apply to the sale of packaged integrated circuit products that TI has qualified and released to market. Additional terms may apply to the use or sale of other types of TI products and services.

Reproduction of significant portions of TI information in TI data sheets is permissible only if reproduction is without alteration and is accompanied by all associated warranties, conditions, limitations, and notices. TI is not responsible or liable for such reproduced documentation. Information of third parties may be subject to additional restrictions. Resale of TI products or services with statements different from or beyond the parameters stated by TI for that product or service voids all express and any implied warranties for the associated TI product or service and is an unfair and deceptive business practice. TI is not responsible or liable for any such statements.

Buyers and others who are developing systems that incorporate TI products (collectively, "Designers") understand and agree that Designers remain responsible for using their independent analysis, evaluation and judgment in designing their applications and that Designers have full and exclusive responsibility to assure the safety of Designers' applications and compliance of their applications (and of all TI products used in or for Designers' applications) with all applicable regulations, laws and other applicable requirements. Designer represents that, with respect to their applications, Designer has all the necessary expertise to create and implement safeguards that (1) anticipate dangerous consequences of failures, (2) monitor failures and their consequences, and (3) lessen the likelihood of failures that might cause harm and take appropriate actions. Designer agrees that prior to using or distributing any applications that include TI products, Designer will thoroughly test such applications and the functionality of such TI products as used in such applications.

TI's provision of technical, application or other design advice, quality characterization, reliability data or other services or information, including, but not limited to, reference designs and materials relating to evaluation modules, (collectively, "TI Resources") are intended to assist designers who are developing applications that incorporate TI products; by downloading, accessing or using TI Resources in any way, Designer (individually or, if Designer is acting on behalf of a company, Designer's company) agrees to use any particular TI Resource solely for this purpose and subject to the terms of this Notice.

TI's provision of TI Resources does not expand or otherwise alter TI's applicable published warranties or warranty disclaimers for TI products, and no additional obligations or liabilities arise from TI providing such TI Resources. TI reserves the right to make corrections, enhancements, improvements and other changes to its TI Resources. TI has not conducted any testing other than that specifically described in the published documentation for a particular TI Resource.

Designer is authorized to use, copy and modify any individual TI Resource only in connection with the development of applications that include the TI product(s) identified in such TI Resource. NO OTHER LICENSE, EXPRESS OR IMPLIED, BY ESTOPPEL OR OTHERWISE TO ANY OTHER TI INTELLECTUAL PROPERTY RIGHT, AND NO LICENSE TO ANY TECHNOLOGY OR INTELLECTUAL PROPERTY RIGHT OF TI OR ANY THIRD PARTY IS GRANTED HEREIN, including but not limited to any patent right, copyright, mask work right, or other intellectual property right relating to any combination, machine, or process in which TI products or services are used. Information regarding or referencing third-party products or services does not constitute a license to use such products or services, or a warranty or endorsement thereof. Use of TI Resources may require a license from a third party under the patents or other intellectual property of the third party, or a license from TI under the patents or other intellectual property of TI.

TI RESOURCES ARE PROVIDED "AS IS" AND WITH ALL FAULTS. TI DISCLAIMS ALL OTHER WARRANTIES OR REPRESENTATIONS, EXPRESS OR IMPLIED, REGARDING RESOURCES OR USE THEREOF, INCLUDING BUT NOT LIMITED TO ACCURACY OR COMPLETENESS, TITLE, ANY EPIDEMIC FAILURE WARRANTY AND ANY IMPLIED WARRANTIES OF MERCHANTABILITY, FITNESS FOR A PARTICULAR PURPOSE, AND NON-INFRINGEMENT OF ANY THIRD PARTY INTELLECTUAL PROPERTY RIGHTS. TI SHALL NOT BE LIABLE FOR AND SHALL NOT DEFEND OR INDEMNIFY DESIGNER AGAINST ANY CLAIM, INCLUDING BUT NOT LIMITED TO ANY INFRINGEMENT CLAIM THAT RELATES TO OR IS BASED ON ANY COMBINATION OF PRODUCTS EVEN IF DESCRIBED IN TI RESOURCES OR OTHERWISE. IN NO EVENT SHALL TI BE LIABLE FOR ANY ACTUAL, DIRECT, SPECIAL, COLLATERAL, INDIRECT, PUNITIVE, INCIDENTAL, CONSEQUENTIAL OR EXEMPLARY DAMAGES IN CONNECTION WITH OR ARISING OUT OF TI RESOURCES OR USE THEREOF, AND REGARDLESS OF WHETHER TI HAS BEEN ADVISED OF THE POSSIBILITY OF SUCH DAMAGES.

Unless TI has explicitly designated an individual product as meeting the requirements of a particular industry standard (e.g., ISO/TS 16949 and ISO 26262), TI is not responsible for any failure to meet such industry standard requirements.

Where TI specifically promotes products as facilitating functional safety or as compliant with industry functional safety standards, such products are intended to help enable customers to design and create their own applications that meet applicable functional safety standards and requirements. Using products in an application does not by itself establish any safety features in the application. Designers must ensure compliance with safety-related requirements and standards applicable to their applications. Designer may not use any TI products in life-critical medical equipment unless authorized officers of the parties have executed a special contract specifically governing such use. Life-critical medical equipment is medical equipment where failure of such equipment would cause serious bodily injury or death (e.g., life support, pacemakers, defibrillators, heart pumps, neurostimulators, and implantables). Such equipment includes, without limitation, all medical devices identified by the U.S. Food and Drug Administration as Class III devices and equivalent classifications outside the U.S.

TI may expressly designate certain products as completing a particular qualification (e.g., Q100, Military Grade, or Enhanced Product). Designers agree that it has the necessary expertise to select the product with the appropriate qualification designation for their applications and that proper product selection is at Designers' own risk. Designers are solely responsible for compliance with all legal and regulatory requirements in connection with such selection.

Designer will fully indemnify TI and its representatives against any damages, costs, losses, and/or liabilities arising out of Designer's non-compliance with the terms and provisions of this Notice.